

VALU
GUIDE®

BEVERAGE COMPANY SAVES OVER \$104,000 ANNUALLY

BOTTLE LINE PRODUCTIVITY INCREASED WITH GUIDERAIL CHANGEOVER SOLUTION

INDUSTRY/APPLICATION

Beverage Bottling Conveyor

SOLUTION TYPE:

Increased Production, Decreased Labor Costs

PROBLEM

A large sports beverage company produces 750 bottles per minute, which is 25,000 bottles per hour. To accommodate the different sized beverage containers on the same conveyor line, maintenance personnel were spending 2hrs per week and \$15,000 in lost revenue to make conveyor guide rail adjustments that were required. This changeover activity also detracted maintenance personnel from working on higher value tasks throughout the week.

SOLUTION

After evaluation, the Perceptiv™ intelligence team offered a unique technical solution – Valu Guide® side rails and SpeedSet™ brackets, with complete installation provided. The versatility of SpeedSet brackets allow for guide rail adjustability without the need for tools. Each rail holding point is adjusted by inserting a spacer, saving valuable time on line changeovers. After the SpeedSet brackets were installed, the maintenance team reduced their line changeover time from 2hrs to only 30 minutes, with a profit increase of over \$104,000 and a labor savings of approximately \$1,700 annually!

BENEFITS SEEN BY THE PLANT INCLUDED

- \$104,000 increased profit and \$1,700 labor savings annually
- Simplicity of line changeovers
- Increased production, decreased labor costs, more time to spend on higher value tasks



System Plast® Speedset™ brackets allow for faster and easier rail guide adjustments.

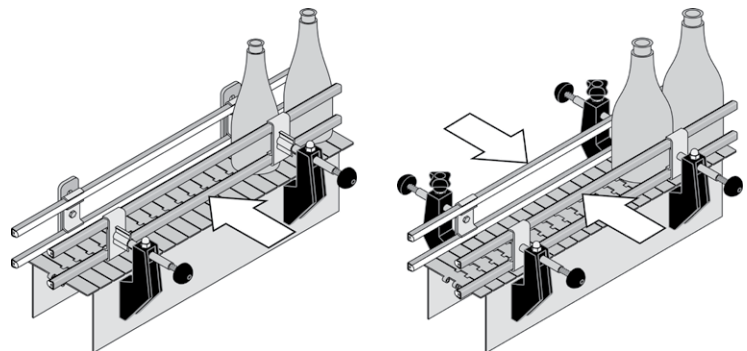

INSIGHT. IN REACH.

At Regal, we're always looking ahead. Now, we have the technology to look even further. Perceptiv™ intelligence is an interconnected matrix of smart, digital solutions using cloud-based technology to track, report, communicate and share performance data, in order to empower and elevate our customers for continuous improvement.



CONNECTED PRODUCTS

These are the enabled components and products that bring Perceptiv™ intelligence to life. From monitoring systems and motors, to sensors to QR tags – our hardware keeps you connected to the cloud to maximize benefits of your preventative maintenance activities.



CONNECTED SERVICES

When you can see it all, you can predict the future. From diagnostic services to easily accessible dashboards, Perceptiv intelligence connects you to Regal's real-time monitoring and solutions.



INTERACTIVE PRODUCT CONTENT

Use our library of interactive images, CAD, and comparison tools to spec, source and repair for your equipment. With Perceptiv intelligence, you'll see Regal® products like you've never seen them before.



ONLINE TOOLS

Designing a Regal product into your application? Perceptiv intelligence has the answer. Browse our online tools for selection programs, calculators, mobile apps, registration modules and more.



ECOMMERCE

No matter what you need, Perceptiv intelligence puts it all in one place 24/7. Log in to buy directly or through connected systems anytime from anywhere.

Perceptiv™

**SYSTEM
PLAST®**

Regal Beloit America, Inc.
7120 New Buffington Road
Florence, KY 41042
Phone: 1-800-606-2093, Ext. 7
info@Perceptiv.com

regalbeloit.com/Perceptiv

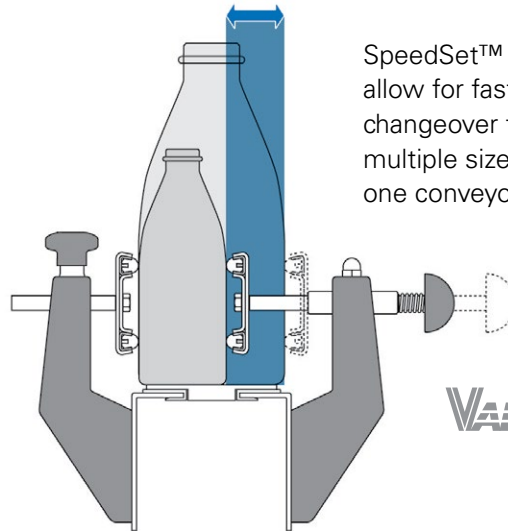

SpeedSet™ brackets allow for fast and tool-free changeover for running multiple size containers on one conveyor.

VALU
GUIDE®

APPLICATION CONSIDERATIONS

The proper selection and application of products and components, including the related area of product safety, is the responsibility of the customer. Operating and performance requirements and potential associated issues will vary appreciably depending upon the use and application of such products and components. The scope of the technical and application information included in this publication is necessarily limited. Unusual operating environments and conditions, lubrication requirements, loading supports, and other factors can materially affect the application and operating results of the products and components and the customer should carefully review its requirements. Any technical advice or review furnished by Regal Beloit America, Inc. and/or its affiliates ("Regal") with respect to the use of products and components is given in good faith and without charge, and Regal assumes no obligation or liability for the advice given, or results obtained, all such advice and review being given and accepted at customer's risk.

For a copy of our Standard Terms and Conditions of Sale, please visit <https://www.regalbeloit.com/Terms-and-Conditions-of-Sale>. These terms and conditions of sale, disclaimers and limitations of liability apply to any person who may buy, acquire or use a Regal product referred to herein, including any person who buys from a licensed distributor of these branded products.

Regal, Perceptiv, SpeedSet, System Plast and Valu Guide are trademarks of Regal Beloit Corporation or one of its affiliated companies.

©2020, 2021 Regal Beloit Corporation, All Rights Reserved. MCF520009E • Form# 10250E

REGAL®